

Ball valves

Three and Four way

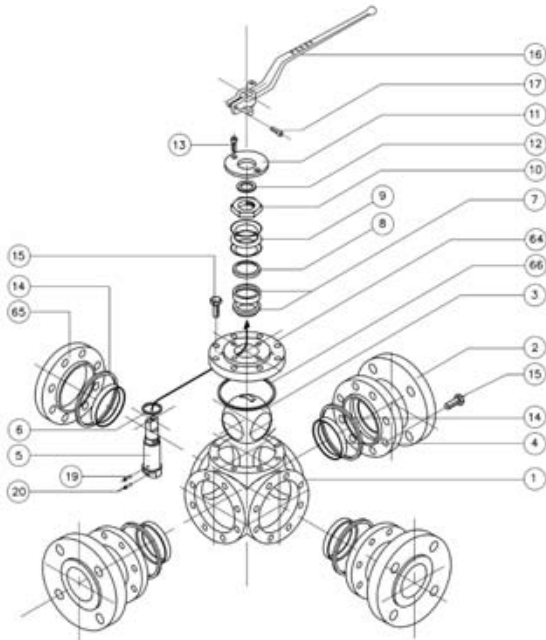

Standard construction materials



POS	DENOMINACION	DESCRIPTION	CANT.	MATERIALS / MATERIAL				
				DIN			ANSI	
				FIG.81TTT	FIG.84TTT	FIG.86TTT	FIG.84TTT	FIG.86 TTT
1	Cuerpo	Body	1	GG 25	1.0619	1.4408	A216.WCC	A351.CF8M
2	Lateral	End cap	3	GG 25	1.0619	1.4408	A216.WCC	A351.CF8M
3	Bola	Ball	1	1.4408	1.4408	1.4408	A351.CF8M	A351.CF8M
4	Asiento	Seat	4	PTFE	PTFE	PTFE	PTFE	PTFE
5	Eje	Stem	1	14401	14401	14401	AISI 316	AISI 316
6	Junta eje	Stem seal	1	PTFE + FV	PTFE + FV	PTFE + FV	PTFE + FV	PTFE + FV
7	Estopada	Packing ring	2	PTFE	PTFE	PTFE	PTFE	PTFE
8	Anillo prensa	Gland packing	1	1.4401	1.4401	1.4401	AISI 316	AISI 316
9	Arandela muelle	Spring washer	3	1.4310	1.4310	1.4310	AISI 301	AISI 301
10	Tuerca eje	Stem nut	1	1.4305	1.4305	1.4305	AISI 303	AISI 303
11	Tapa	Cover	1	1.4408	1.4408	1.4408	1.4408	1.4408
12	Anillo tapa	Cover ring	1	PTFE	PTFE	PTFE	PTFE	PTFE
13	Tornillo Tapa	Cover bolt	2	8.8	8.8	A4-70	8.8	A4-70
14	Junta cuerpo	Body seal	4	PTFE	PTFE	PTFE	PTFE	PTFE
15	Tornillo cuerpo	Body bolt	-	8.8	A2-70	A4-70	A2-70	A4-70
16	Maneta	Handle	1	1.0619	1.0619	1.0619	A216.WCC	A216.WCC
17	Tornillo Maneta	Handle bolt	1	A2-70	A2-70	A2-70	A2-70	A2-70
19	Muelle	Spring	2	1.4319	1.4319	1.4319	AISI 302	AISI 302
20	Bola	Ball	2	1.4401	1.4401	1.4401	AISI 316	AISI 316
64	Tapa cuerpo	Body cover	1	GG 25	1.0619	1.4408	A216.WCC	A351.CF8M
65	Lateral ciego	Blind end cap	1	GG 25	1.0619	1.4408	A216.WCC	A351.CF8M
66	Junta tapa cuerpo	Cover body seal	1	PTFE	PTFE	PTFE	PTFE	PTFE

Dimensions

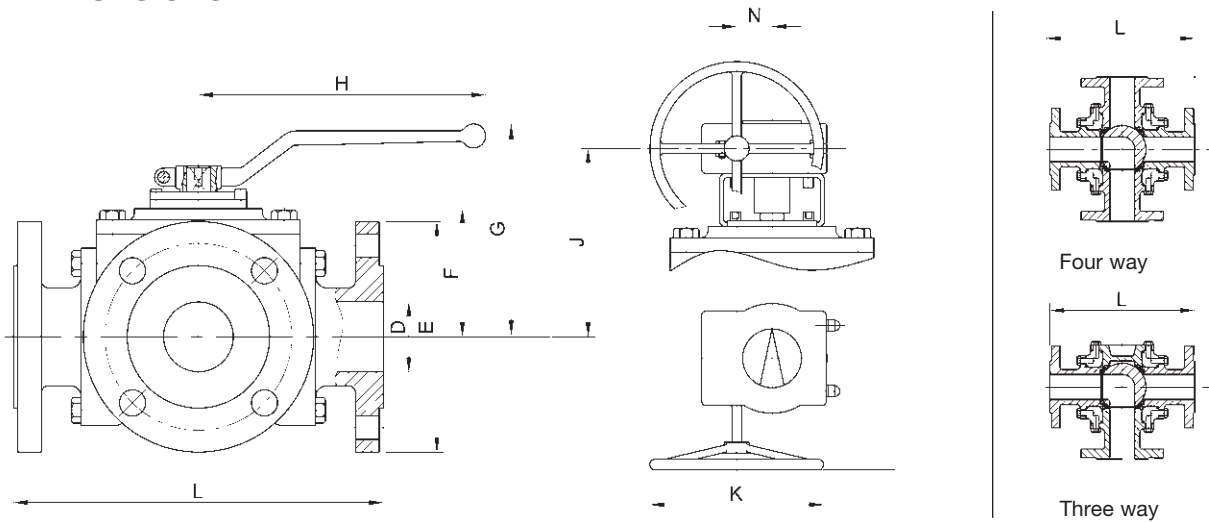

DN / NPS	D	E (DIN)		E(ANSI)		ISO 5211	L	F	G	H	I	J	K	N	Weight Valve (Kg)		
		PN 16	PN 40	150 Lb	300 Lb										Valve	Valve+G.Box	
25	1"	25	115	108	124	F05	230	67	124	185	-	-	-	-	12	-	
40	1 1/2"	40	150	127	156	F07	260	82	147	293	200	198	250	60	23	30	
50	2"	50	165	152	165	F07	290	90	155	293	200	206	250	60	30	37	
65	2 1/2"	65	185	178	190	F10	340	109	190	293	200	225	250	50	48	55	
80	3"	80	200	190	210	F12	380	132	229	740	200	241	250	68	70	78	
100	4"	100	220	235	229	254	F12	430	147	250	740	270	268	315	68	95	106
150	6"	150	285	300	280	318	F14	480	216	310	750	300	356	400	96	178	205
200	8"	200	340	375	343	381	F14	600	258	350	750	310	398	500	96	300	330
250	10"	250	405	450	406	445	F16	775	372	-	-	320	542	500	96	375	405
300	12"	300	460	515	483	521	F16	850	395	-	-	400	570	600	137	765	815

Top Flange ISO 5211

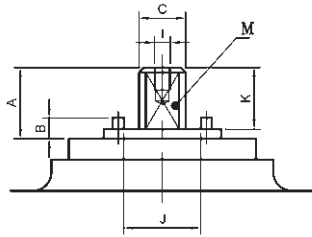

ISO 5211	F05	F07		F10	F12		F14		F16	
M (e/c)	10	14		19	26		32		46	
C	16	20		25	34		42		60	
B	6	9		11	13		15		-	
A	22	25		27	38		43		73	
K	19	22		24	35		40		70	
J	24	34		43	52		62		-	
I	M4	M6		M8	M8		M8		M8	
DN	25	40	50	65	80	100	150	200	250	300
SIZE	1"	1 1/2"	2"	2 1/2"	3"	4"	6"	8"	10"	12"

3 way "T" configurations

Standard

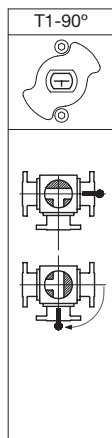

Other

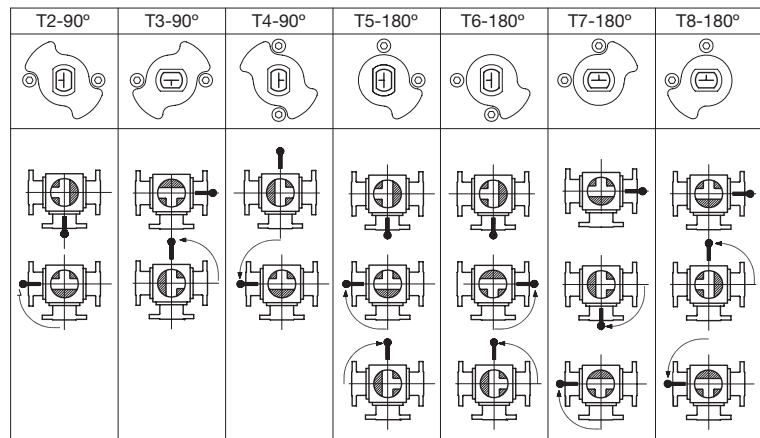

3 way "L" configuration

Standard
Estándar

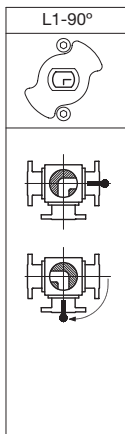

Other
Otras

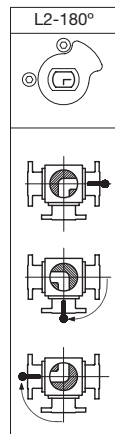

Vertical "L"
Vertical "L"

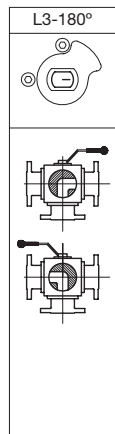

4 way configurations

4 way configurations
Configuraciones 4 vías

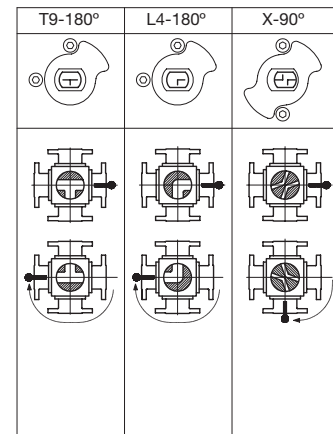

Break away torques (Nm)

PORT	DN	25	40	50	65	80	100	150	200	250	300
IN "L"		30	78	105	156	220	350	480	850	1500	2100
IN "T"		33	80	110	170	240	385	530	980	1650	2400
IN "X"		35	85	115	178	250	396	550	995	1705	2560

* Test are made with water and PTFE seats at 16 bars
The "S" and "R" seats must increase the break away torque by 30%

“L” Port construction

DN	25	40	50	65	80	100	150	200	250	300
NPS	1”	1 1/2”	2”	2/12”	3”	4”	6”	8”	10”	12”
Kv	25	60	85	148	295	380	750	1300	1955	2830

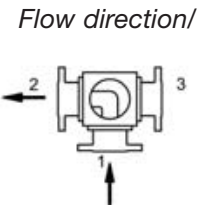

“T” and “X” Port construction

DN		25	40	50	65	80	100	150	200	250	300
NPS		1”	1 1/2”	2”	2 1/2”	3”	4”	6”	8”	10”	12”
Kv	(A) PORT 2	20	51	75	136	215	340	705	905	1300	1956
	(B) PORT 1	23	60	90	141	338	380	815	995	1453	2100
	(B) PORT 2	58	160	270	510	812	1380	2650	4603	5230	6100
	(C) PORTS 2/3	24	58	85	144	218	340	767	1150	1840	2860
	(D) PORT 2/4	60	170	292	532	858	1425	2800	4820	5850	6734
(E) PORTS 2/4	16	39	60	101	154	242	542	867	1430	2410	

Flow direction /

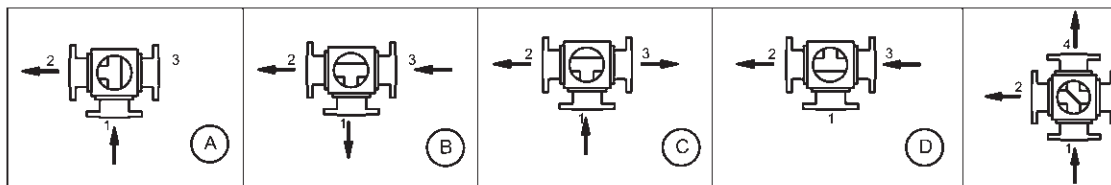

P-T Diagram

