

# Heating jacket ball valves

## Válvulas de bola con cámara de calefacción

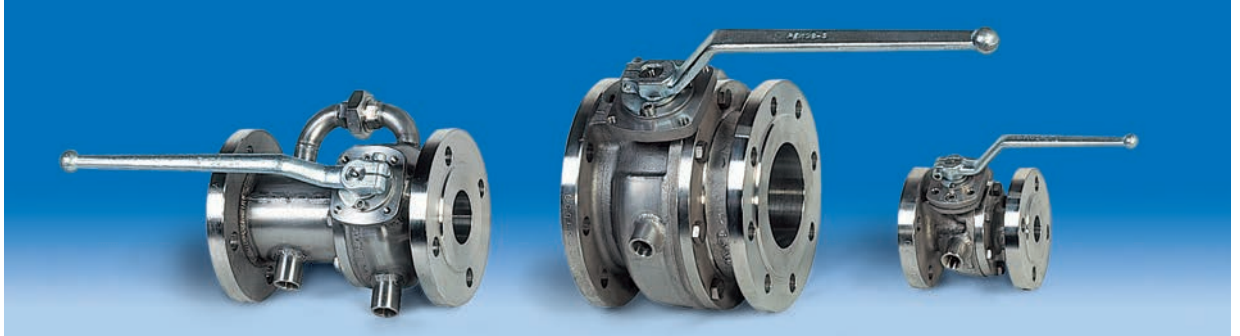

### Design advantages / Ventajas del diseño

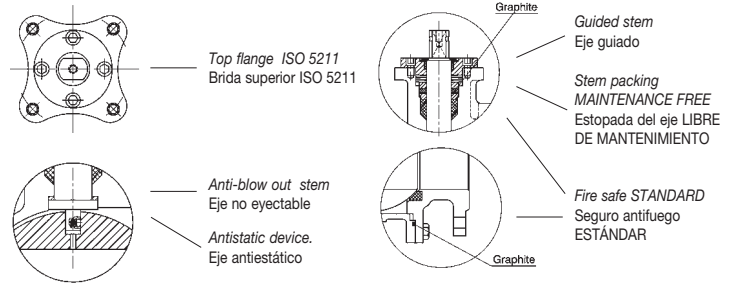
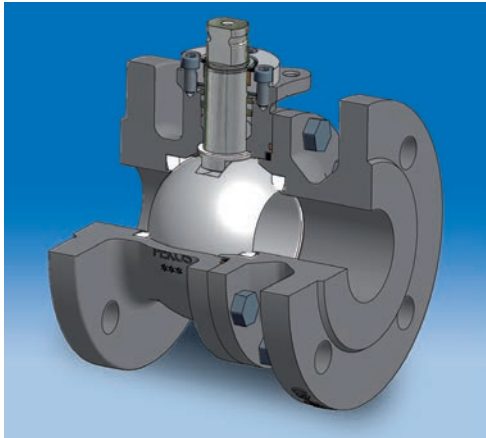

### Standard construction materials / Materiales de construcción estándar

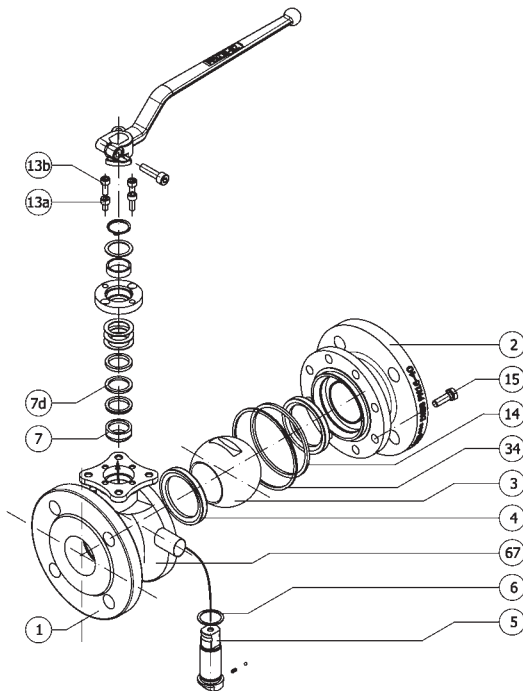

Item	Description	Descripción	Cant	Fig. ZH 04RRRG_		Fig. ZH 06RRRG_	
1	Body 1	Cuerpo 1	1	1.0619	C.S.	1.4408	S.S
2	Body 2	Cuerpo 2	1	1.0619	C.S	1.4408	S.S
3	Ball	Bola	1	1.4408	S.S	1.4408	S.S
4	Seats	Asiento	2	PTFE + FG	(R)	PTFE + FG	(R)
5	Stem	Eje	1	1.4401	S.S	1.4401	S.S
6	Stem washer	Junta eje	1	PTFE + FG	(R)	PTFE + FG	(R)
7	Packing	Estopada	1	PTFE + FG	(R)	PTFE + FG	(R)
7d	Packing 1	Estopada 1	1	Graphite	(G)	Graphite	(G)
13a	Cover bolt	Tornillo tapa	2/4	A4-70	S.S	A4-70	S.S
13b	Stop bolt	Tornillo tope	2	A4-70	S.S	A4-70	S.S
14	Body seal 1	Junta cuerpo 1	1	PTFE + FG	(R)	PTFE + FG	(R)
15	Body bolt	Tornillo cuerpo	1	A4-70	S.S	A4-70	S.S
34	Body seal 2	Junta cuerpo 2	1	Graphite	(G)	Graphite	(G)
67	Cover heating	Carcasa calef.	1	1.4301	S.S	1.4301	S.S

## Heating jacket ball valves

## Válvulas de bola con cámara de calefacción

### Dimensions / Dimensiones

According to DIN 3202 F4 / Según DIN 3202 F4

DN	15	20	25	40	50	65	80	100	150	200
A	47	50	56	56	68	82	81	91	165	200
B	157	161	169	194	207	241	252	284	354	384
D	3/8" BSPP			1/2 " BSPP						
L	115	120	125	140	150	170	180	190	350	400

Under request manufactured up to DN-300.  
Bajo demanda se fabrican hasta DN-300.

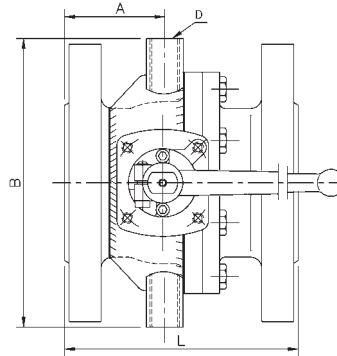

According to DIN 3202 F1 / Según DIN 3202 F1

DN	15	20	25	40	50	65	80	100
A	47	50	56	56	65	82	81	91
B	81	83	85	106	114	133	142	148
C	30	30	30	61	61	98	102	118
D	3/8" BSPP			1/2 " BSPP				
E	62	69	71	85	92	104	111	121
F	43	50	52	63	70	82	89	99
L	130	150	160	200	230	290	310	350

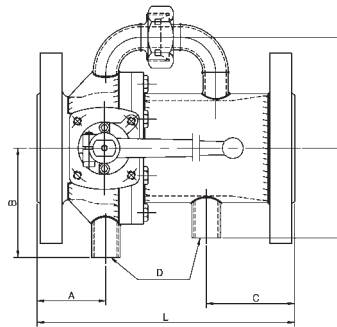

DIN 3202 F1 with flanges / DIN 3202 F1 con bridas

DN	15	20	25	40	50	65	80	100
A	45	50	51	56	64	76	81	91
B	95	110	110	132	150	160	165	185
C	27	30	34	57	57	57	57	57
E	15	15	15	25	25	25	25	25
L	130	150	160	200	230	290	310	350

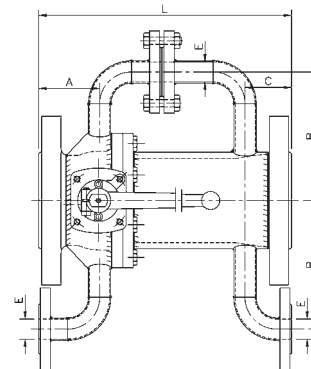

### Others / Varios

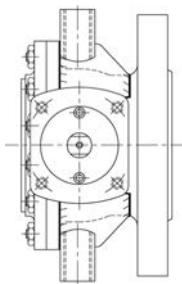

Tank bottom valve  
Fondo de cuba

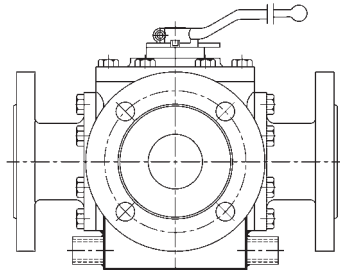

Three way valve  
Válvula de tres vías

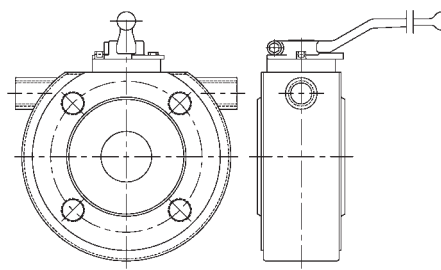

Wafer type valve  
Válvula tipo wafer

### Specifications / Especificaciones

Welding procedure of jackets according to performed Code ASME Section IX, EN 288 and EN 287.  
Procedimiento de soldadura de acuerdo al Código ASME Sección IX, EN 288 y EN 287.