

CHFM200 - bonneted, rising stem

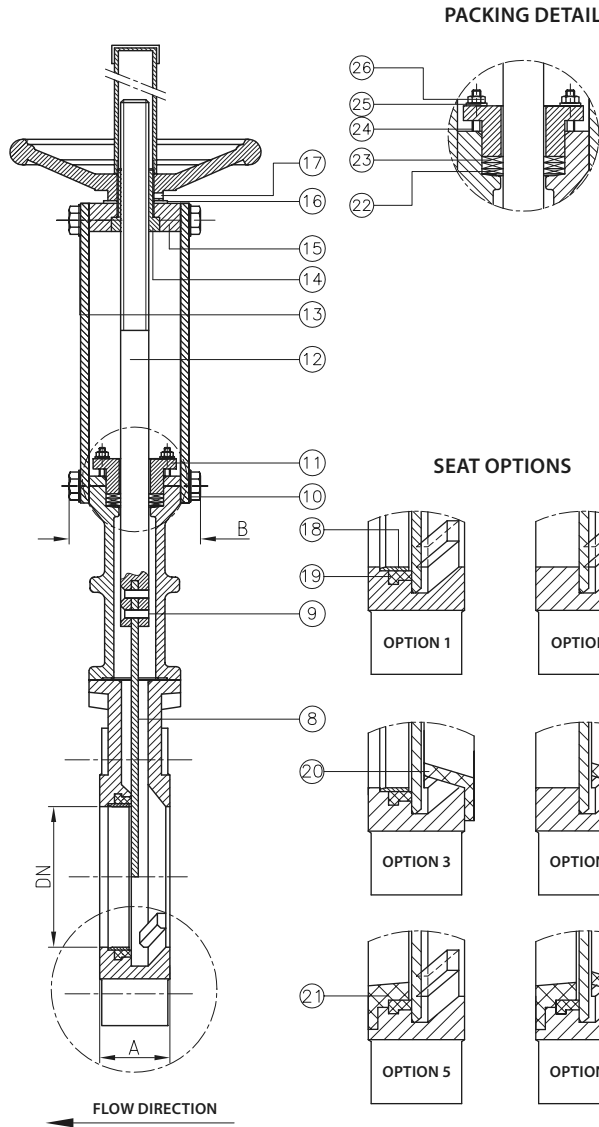
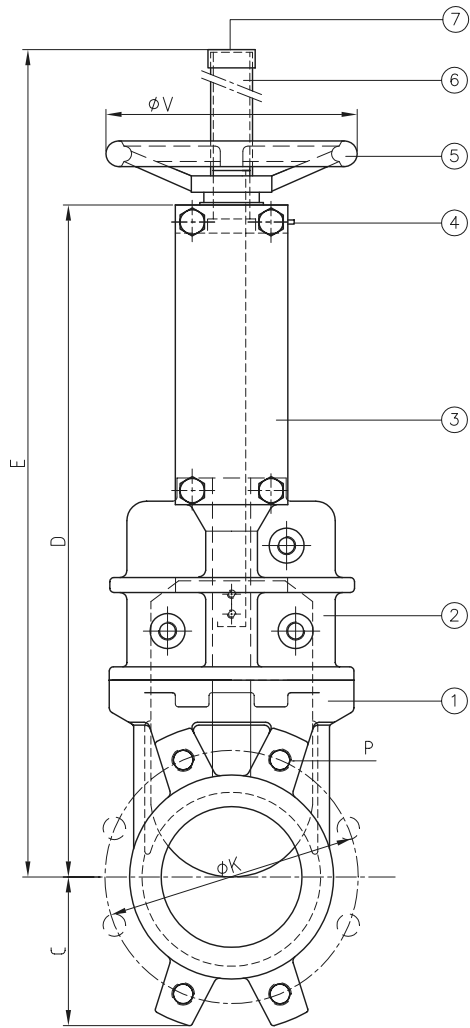

Dimensions [mm]*

DN	INCH	A	B	C	D	E	ϕV	ϕK PN10	ϕK ANSI150	P PN10	P ANSI150
50	2"	40	90	60	340	498	200	125	120,6	4 x M16	4 x W 5/8"
65	2 1/2"	40	90	68	391	533	200	145	139,7	4 x M16	4 x W 5/8"
80	3"	50	90	90	434	580	200	160	152,4	8 x M16	4 x W 5/8"
100	4"	50	90	105	519	665	200	180	190,5	8 x M16	8 x W 5/8"
125	5"	50	100	118	536	723	250	210	215,9	8 x M16	8 x W 3/4"
150	6"	60	100	135	568	800	250	240	241,3	8 x M20	8 x W 3/4"
200	8"	60	120	170	737	1035	300	295	298,4	8 x M20	8 x W 3/4"
250	10"	70	120	202	930	1325	300	350	361,9	12 x M20	12 x W 7/8"
300	12"	70	120	240	1015	1410	300	400	431,8	12 x M20	12 x W 7/8"
350	14"	96	192	255	1175	1710	400	460	476,2	16 x M20	12 x W 1"
400	16"	100	192	295	1310	1855	400	515	539,7	16 x M24	16 x W 1"
450	18"	106	192	318	1465	2000	500	565	577,8	20 x M24	16 x W 1 1/8"
500	20"	110	192	345	1593	2135	500	620	635	20 x M24	20 x W 1 1/8"
600	24"	110	290	405	1875	2495	500	725	749,3	20 x M27	20 x W 1 1/4"

Materials*

	Cast Iron Type	Stainless Steel Type
1 Body	GG25	1.4408/SS316
2 Bonnet	GG25	1.4408/SS316
3 Support plate		Steel
4 Greasing nipple		Standard
5 Handwheel		GG25
6 Tube		Steel
7 Cover		Plastic
8 Gate	SS304L	SS316L
9 Union studs stem-gate		A2
10 Bolts		A2
11 Packing gland	Steel	1.4408/SS316
12 Stem		1.4305/SS303
13 Grower washer		A2
14 Manoeuvring nut		Brass
15 Support bridge		Steel
16 Washer		A2
17 Pin		A2
18 Ring	1.4301/SS304	1.4408/SS316
19 Seat	EPDM / NBR / Viton / Silicon / Flucast ABP / PTFE	
20 Deflecting cone	1.4301/SS304	1.4408/SS316
21 Scraper 8°	1.4301/SS304	1.4408/SS316
22 Packing	Synt. + PTFE / PTFE / Graphite / Ceramic fibre	
23 Packing o-ring	EPDM / NBR / Viton / PTFE	
24 Studs		A2
25 Washer		A2
26 Nut		A2

Maximum working pressure recommended

DN50 - DN250:	10 bar
DN300 - DN400:	6 bar
DN450:	5 bar
DN500 - DN600:	4 bar

Higher pressure on request [reinforced design]

Colour*

 RAL 5015

Flanges drilled according to EN 1092-2 and DIN 2501: ISO PN10 or ANSI 150 (for further informations please visit our download section on our website)

*Other dimensions / materials / colours on request.